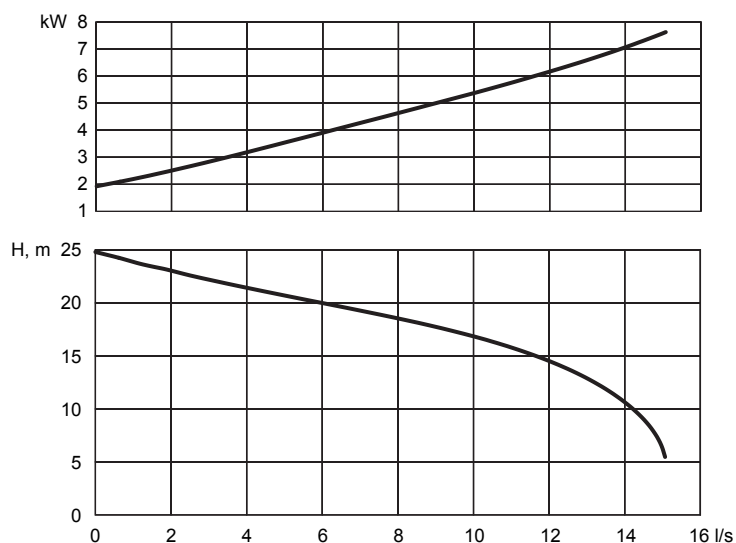
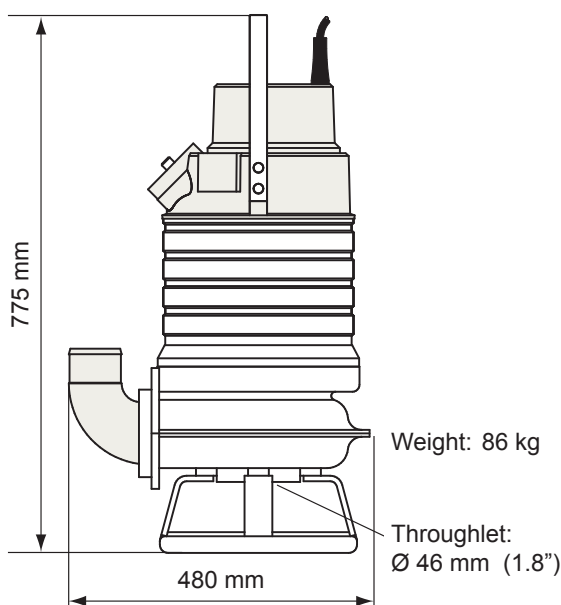

SANDY INOX*Electrical submersible sludge pump***60 Hz**www.grindex.com**INOX****Classification**

Electrical submersible pump
Protection class: IP68, 20m

Electrical motor

Squirrel cage induction motor
Insulation class: F (IEC 85)

Technical data

Shaft speed	r.p.m.	3400
Rated output	kW	6.7
Max. power cons.	kW	7.6
Rated current A at	230 V	22
	460 V	11
	575 V	9

Other voltages on request

Motor protector (optional)

Phase sequence control, phase failure guard, temperature guard with thermal contacts in the stator (= SMART-system), DOL or star/delta.

Air valve

Power cable (optional)

H07RN8-F, length 20m
4x4mm², U=230 V
4x2.5mm², U=460-575 V

Without built-in starter:

**This pump must be used with external motor protection.
Use rated current when sizing control equipment.**

Shaft seals

Double mechanical shaft seals with an oil compartment between the seals

Material lower seal: Silicon carbide - silicon carbide
Material upper seal: Carbon - silicon carbide

Bearings

Lower: Double angular contact ball bearing with C3 clearance
Upper: Ball bearing with C3 clearance

Discharge connection

3", hose, BSP or NPT threaded

Materials

Casted parts	Stainless steel (EN 10283-1.14412)
Outer casing	Stainless steel (EN 10088-3-1.14436)
Motor shaft	Stainless steel (EN 10088-3-1.14460)
Impeller	Stainless steel (EN 10283-1.14412)
Screws and nuts	Stainless steel (A4)
O-rings	Viton rubber
Pump housing	Nitrile rubber

Accessories

Built-in motor protection kit
Zinc anodes

Limitations

Max. submersion depth: 20 m
Max. liquid temperature: 40°C
Max. liquid density: 1100 kg/m³
pH of the liquid: 2-10

Specifications can be changed without notice.