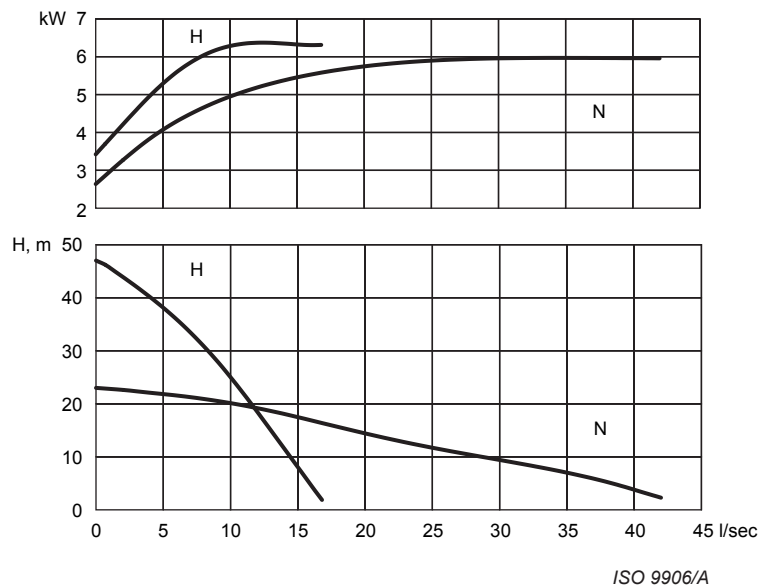
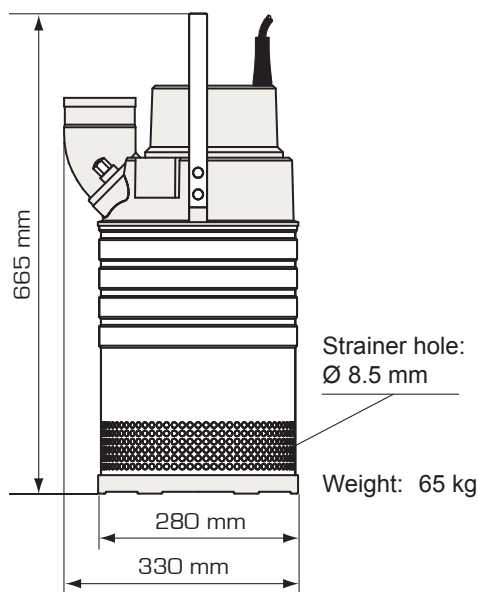

MAJOR INOX*Electrical submersible drainage pump**60 Hz*www.grindex.com**INOX****Pump types**

N: Normal pressure

H: High pressure

Classification

Electrical submersible pump

Protection class: IP68, 20m

Electrical motor

Squirrel cage induction motor

Insulation class: F (IEC 85)

Technical data

		N	H
Shaft speed	r.p.m.	3400	3400
Rated output	kW	6.7	6.7
Max. power cons.	kW	6.0	6.4
Rated current A at	230 V	17	18
	460 V	8.7	9.2
	575 V	6.9	7.4

*Other voltages on request***Motor protector (optional)**

Phase sequence control, phase failure guard, temperature guard with thermal contacts in the stator (= SMART-system), DOL or star/delta.

Air valve

Power cable (optional)

H07RN8-F, length 20m

4x2.5mm², U=230-575 V**Without built-in starter:****This pump must be used with external motor protection.****Use rated current when sizing control equipment.****Shaft seals**

Double mechanical shaft seals with an oil compartment between the seals

Material lower seal: Silicon carbide - silicon carbide

Material upper seal: Carbon - silicon carbide

Bearings

Lower: Double angular contact ball bearing with C3 clearance

Upper: Ball bearing with C3 clearance

Discharge connection

3-4", hose, BSP or NPT threaded

Materials

Casted parts	Stainless steel (EN 10283-1.14412)
Outer casing	Stainless steel (EN 10088-3-1.14436)
Motor shaft	Stainless steel (EN 10088-3-1.14460)
Impeller	Stainless steel (EN 10283-1.14412)
Screws and nuts	Stainless steel (A4)
O-rings	Viton rubber
Diffusers	Nitrile rubber

Accessories

Built-in motor protection kit

Zinc anodes

Limitations

Max. submersion depth: 20 m

Max. liquid temperature: 40°C

Max. liquid density: 1100 kg/m³

pH of the liquid: 2-10

Specifications can be changed without notice.