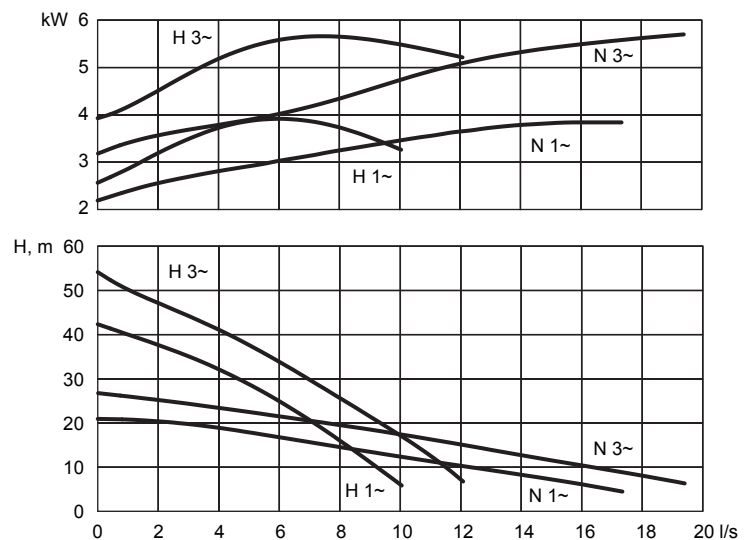
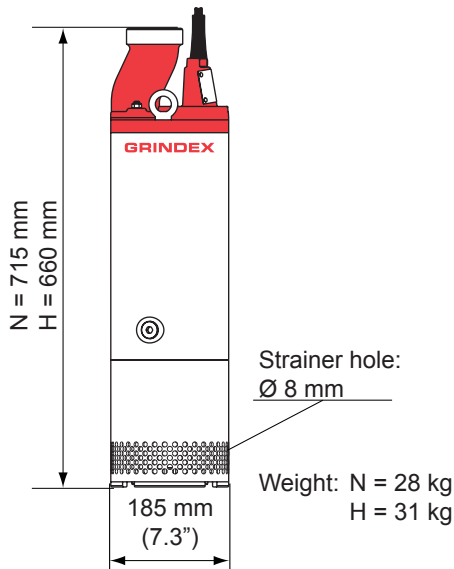

TUBO 8"*Electrical submersible drainage pump***60 Hz**www.grindex.com**TUBO**

ISO 9906/A

Pump types

1~ 1-phase

3~ 3-phase

N: Normal pressure

H: High pressure

Classification

Electrical submersible pump

Protection class: IP68, 20 m

Electrical motor

Squirrel cage induction motor

Insulation class: F (IEC 85)

Technical data

		1~	3~
Shaft speed	r.p.m.	3400	3400
Rated output	kW	3.1	4.5
Max. power cons.	kW	4.0	5.7
Rated current A at	230V	18	16
	460V		8

*Other voltages on request***Power cable**

HO7RN8-F, length 20 m

4x2.5 mm² + 2x1.5 mm²

This pump must be used with external motor protection in accordance with technical data.

Shaft seals

Double mechanical shaft seals with an oil compartment between the seals

Material lower seal: Silicon carbide - silicon carbide

Material upper seal: Carbon - silicon carbide

Bearings

Lower: Double angular contact ball bearing with C3 clearance

Upper: Ball bearing with C3 clearance

Discharge connection

BSP or NPT threaded

N: 3"

H: 2"

Materials

Casted parts Aluminium

Outer casing Stainless steel

Motor shaft Stainless steel

Impeller Cr-alloyed white cast iron

Screws and nuts Stainless steel

Diffusers Nitrile rubber

Accessories

Zinc anodes

Limitations

Max. submersion depth: 20 m

Max. liquid temperature: 40°C

Max. liquid density: 1100 kg/m³

pH of the liquid: 5-8

Specifications can be changed without notice.