

Solid Electrical submersible sludge pump

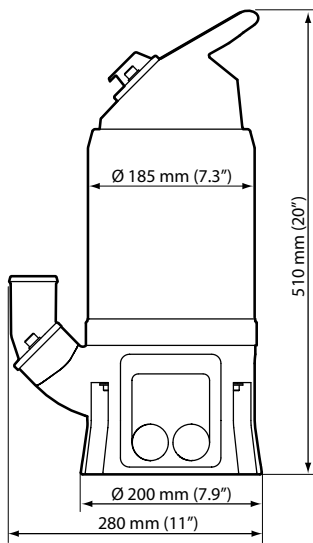

Throughlet:
Ø 38 mm
(1.5")

Weight: 15 kg (33 lb)

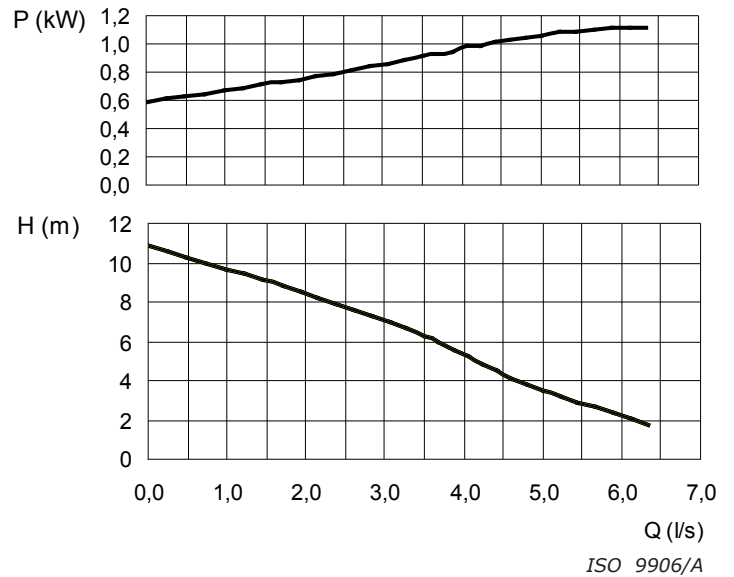

Pump types

Single phase

Classification

Electrical submersible pump

Protection class: IP68

Electrical motor

Squirrel cage induction motor

Insulation class: F (IEC 85)

Technical data

Shaft speed	rpm	3400
Rated output	kW	0.82
Max. power cons.	kW	1.1
Rated current A at	115 V	9.8
	230 V	4.8

Motor protector

Temperature guard with Auto-Cut, automatically cut the power if temperature rise above 135°C (275°F).

Power cable

H07RN-F, 3x1 mm², length 10m
or SOW 16AWG/3, length 16m

Shaft seals

Double mechanical shaft seals with an oil compartment between the seals

Material lower seal: Silicon carbide - silicon carbide

Material upper seal: Carbon - aluminum oxide

Bearings

Ball bearing with C3 clearance

Discharge connection

2", hose, BSP or NPSM

Materials

Pump top	Stainless steel/Reinforced polymer
Outer casing	Stainless steel
Stator housing	Stainless steel
Motor shaft	Stainless steel
Impeller	Polyurethane
Pump housing	Polyurethane
Screws and nuts	Stainless steel

Accessories

Float switch

Limitations

Max. submersion depth: 5 m (16.5 ft)

Max. liquid temperature: 35°C (95°F)

Max. liquid density: 1100 kg/m³

pH of the liquid: 3-9

Specifications can be changed without notice.