

SENIOR

Electrical submersible sludge pump

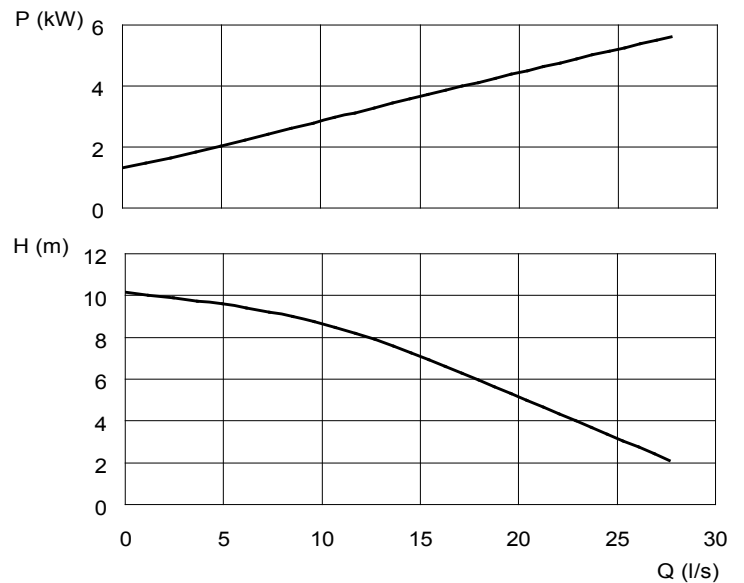
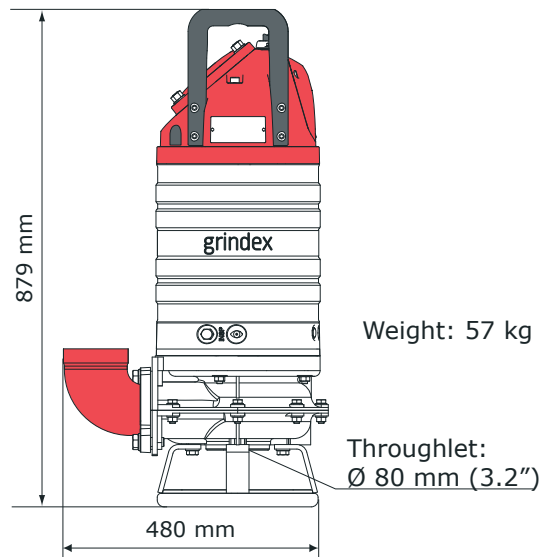

ISO 9906/A

Classification

Electrical submersible pump
Protection class: IP68

Electrical motor

Squirrel cage induction motor
Insulation class H (IEC 85)

Technical data

Shaft speed	rpm	1700
Rated output	kW	4.5
Max. power cons.	kW	5.7
Rated current A at	230 V	17
	460 V	8.6
	575 V	6.9

Other voltages on request

Motor protector

Phase sequence control, phase failure guard,
temperature guard with thermal contacts opening
temp 140°C, airvalve (= SMART-system),

Power cable

SUBCAB:

4G2,5mm², lenght 20m, U≤230V

12AWG/4, lenght 16m, U<380V

14AWG/4, lenght 16m, U≥380V

Shaft seals

Cartridge seal with double mechanical shaft seals with
oil compartment between the seals
Material lower seal: Tungsten carbide-Tungsten carbide
Material upper seal: Tungsten carbide-Tungsten carbide

Bearings

Ball bearing with C3 clearance

Discharge connection

4", Hose, ISO-G or NPT

Materials

Casted parts	Aluminium
Outer casing	Stainless steel
Stator housing	Aluminium
Motor shaft	Stainless steel
Impeller	High chrome alloyed white cast iron
Pump housing	Polyurethane
Screws and nuts	Stainless steel
O-rings	Nitrile rubber

Accessories

Zink anodes

Limitations

Max. submersion depth: 20 m

Max. liquid temperature: 40°C

Max. liquid density: 1100 kg/m³

pH of the liquid: 5-8

Specifications can be changed without notice.